

MIT MUFFENANSCHLUSS, EMPFOHLEN FÜR DEN EINSATZ AN MASCHINEN MIT MITTLERER LEISTUNG.

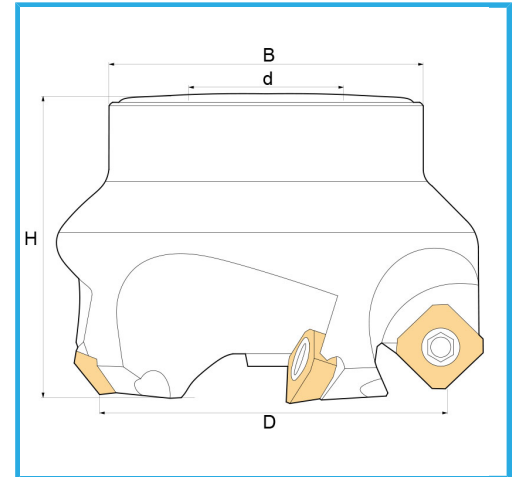

D	100 mm
H	50 mm
B	113 mm
d	32 mm
Z	6
Schrauben	KV500
Einsatz (nicht im Lieferumfang enthalten)	SEHX1204... / SEHT1204...
Bruttogewicht	2,03 kg
Verpackungsmaße	140x140x110 h mm
EAN-Code	8012667181406

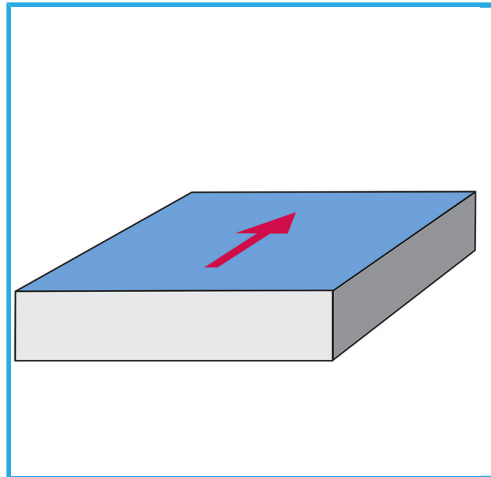

Box



Satiniert



Vernickelt



Extern