

PER IL MONTAGGIO DI UTENSILI CON GAMBO CONICO MORSE.

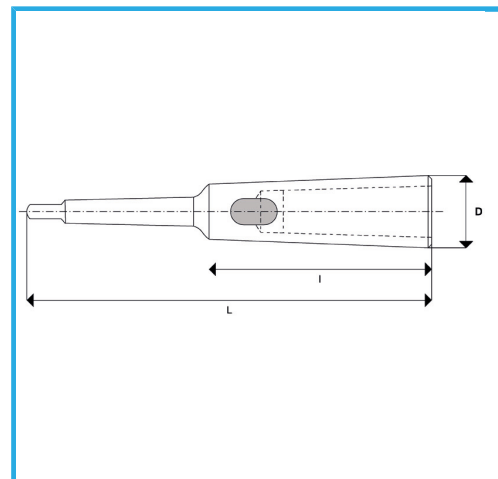

€185,00



CM Esterno	5
CM Interno	6
L	396 mm
I	247 mm
D	82 mm
Peso lordo	6,33 kg
Dimensioni imballo	400 x 100 x 110 h mm
Codice EAN	8012667349752



Scatola



Temprato



Acciaio



Rettificato