

PROF. AUSFÜHRUNG, VERBUNDWERKSTOFF, HANDGRIFF UND KOPF  
AUS SCHLAGABSORBIERENDEM GUMMI. BEDIENUNGSHEBEL,  
WECHSEL DER...

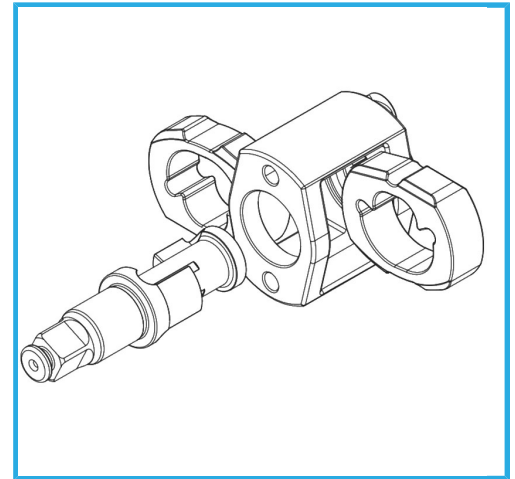

<b>Geschwindigkeit</b>	7300 rpm
<b>max. Drehmoment</b>	1085 Nm   800 lb-ft
<b>geschätzter Luftverbrauch</b>	153 l/min   5.4 SCFM
<b>Betriebsdruck</b>	6 bar   90 psi
<b>Luftanschluss</b>	1/4"
<b>Nettogewicht</b>	2 kg
<b>Verpackungsmaße</b>	230x215x75 h mm
<b>Bruttogewicht</b>	2,22 kg
<b>EAN-Code</b>	8012667346294

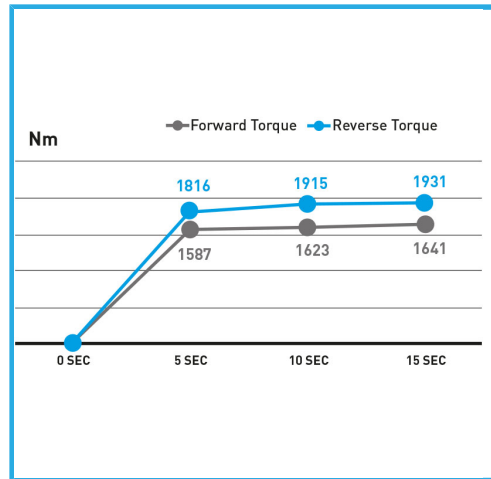

Box



1/2"